



Metoda elementów skończonych (MES1)

Wykład 10A. Przykłady belek

05.2022

Przykład Belka wisząca na linie i podparta dwoma sprężynami.
Zbuduj model MES.

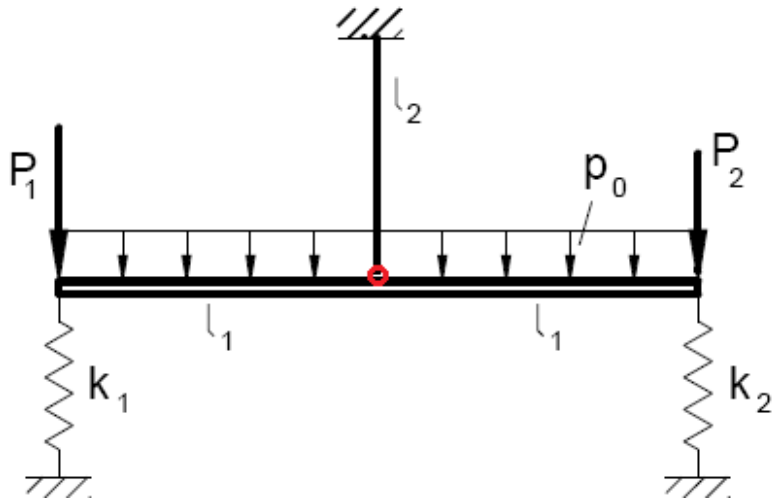

Globalny wektor parametrów węzłowych:

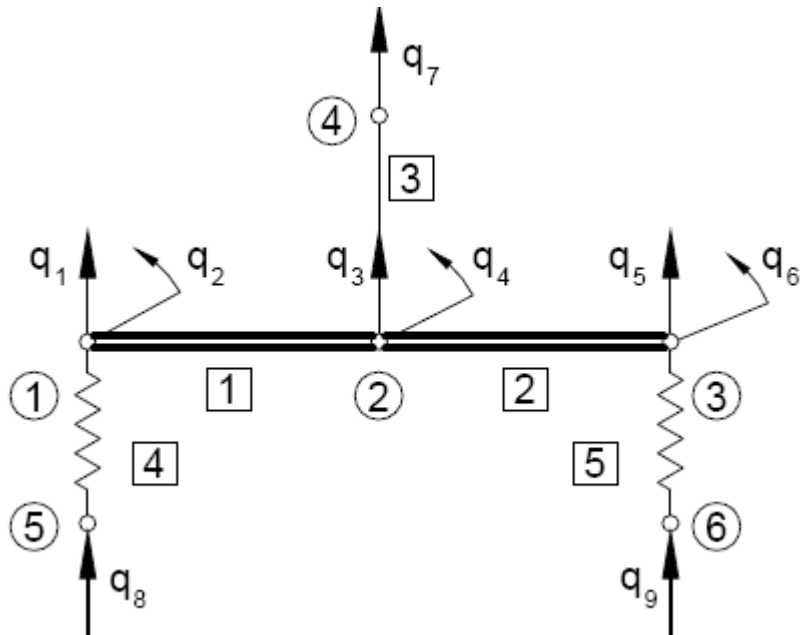

$$\{q\}_g = \begin{Bmatrix} q_1 \\ q_2 \\ q_3 \\ q_4 \\ q_4 \\ q_4 \\ q_7 \\ q_8 \\ q_9 \end{Bmatrix}$$

siły zastępcze dla wydatku stałego:

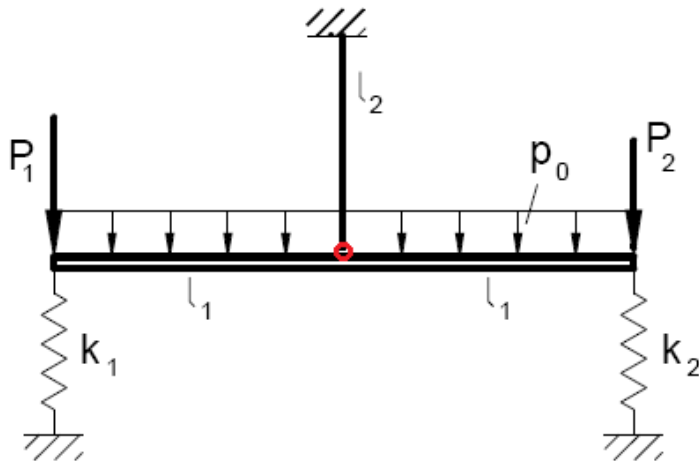
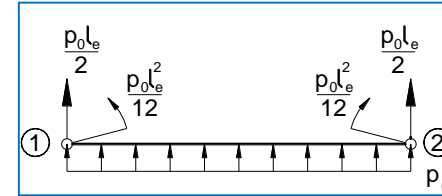

Wektor globalny obciążenia:

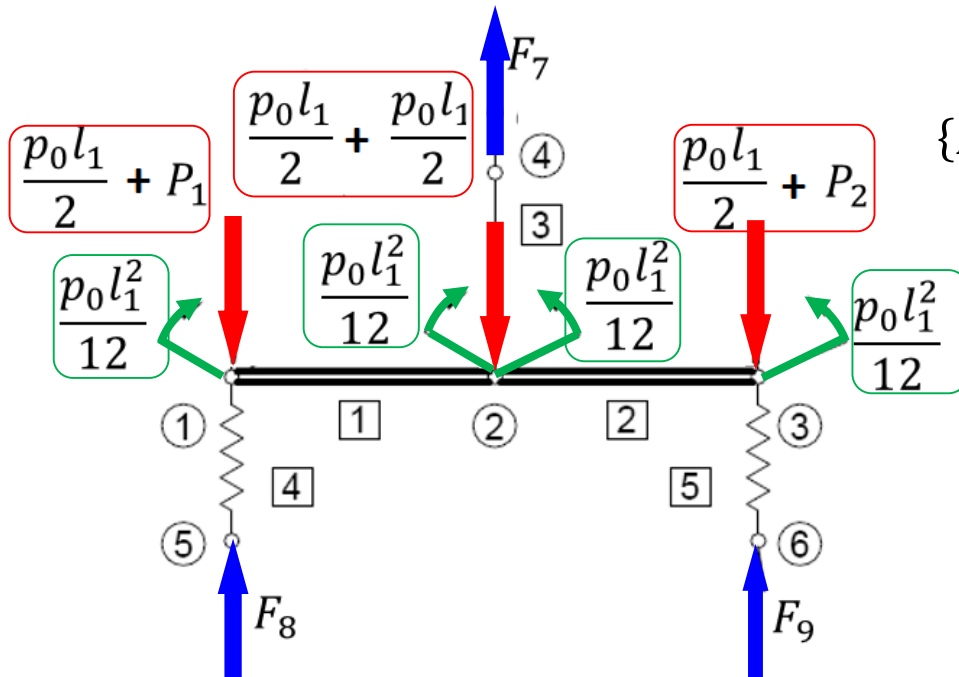

$$\{F\}_g = \begin{Bmatrix} -\frac{p_0 l_1}{2} - P_1 \\ \frac{p_0 l_1^2}{12} \\ -\frac{p_0 l_1}{2} - \frac{p_0 l_1}{2} \\ \frac{p_0 l_1^2}{12} - \frac{p_0 l_1^2}{12} \\ -\frac{p_0 l_1}{2} - P_2 \\ \frac{p_0 l_1^2}{12} \\ F_7 \\ F_8 \\ F_9 \end{Bmatrix} = \begin{Bmatrix} -\frac{p_0 l_1}{2} - P_1 \\ -\frac{p_0 l_1^2}{12} \\ -p_0 l_1 \\ 0 \\ -\frac{p_0 l_1}{2} - P_2 \\ \frac{p_0 l_1^2}{12} \\ F_7 \\ F_8 \\ F_9 \end{Bmatrix}$$

Macierze sztywności elementów:

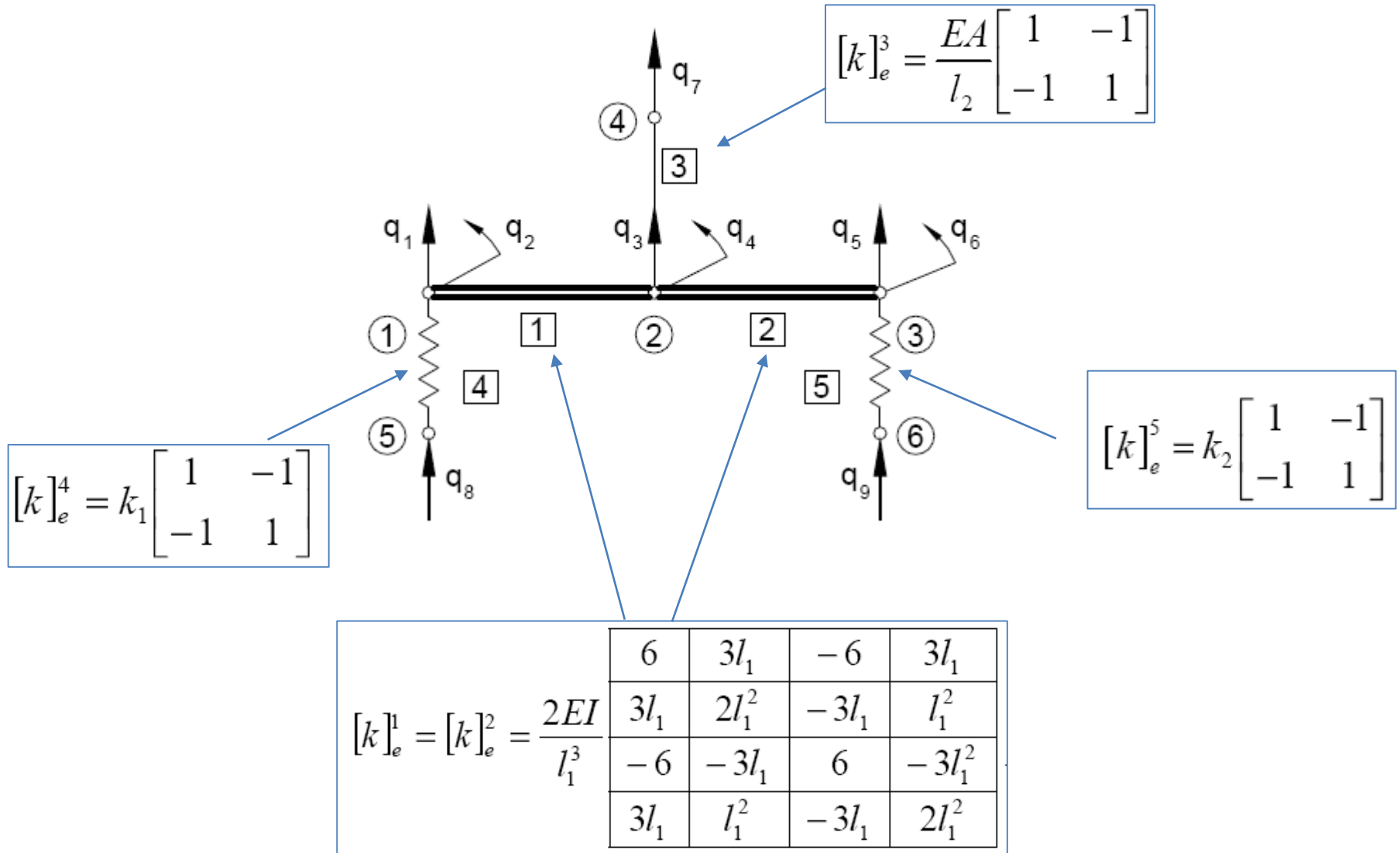

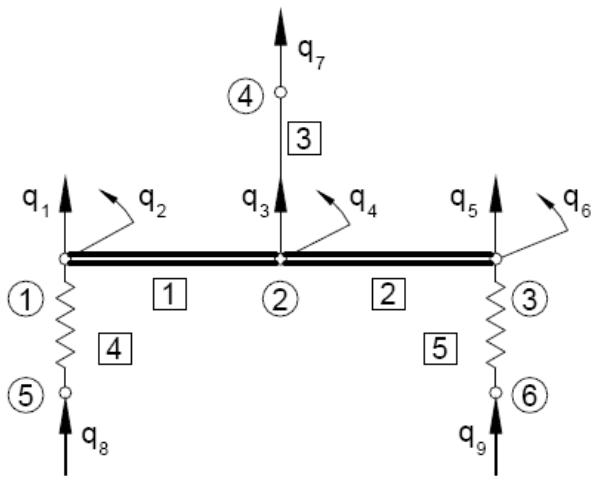

$$[k]_e^1 = [k]_e^2 = \frac{2EI}{l_1^3} \begin{bmatrix} 6 & 3l_1 & -6 & 3l_1 \\ 3l_1 & 2l_1^2 & -3l_1 & l_1^2 \\ -6 & -3l_1 & 6 & -3l_1^2 \\ 3l_1 & l_1^2 & -3l_1 & 2l_1^2 \end{bmatrix}$$

$$[k]_e^3 = \frac{EA}{l_2} \begin{bmatrix} 1 & -1 \\ -1 & 1 \end{bmatrix}$$

$$[k]_e^4 = k_1 \begin{bmatrix} 1 & -1 \\ -1 & 1 \end{bmatrix}$$





$$[k]_e^5 = k_2 \begin{bmatrix} 1 & -1 \\ -1 & 1 \end{bmatrix}$$

Globalna macierz sztywności:

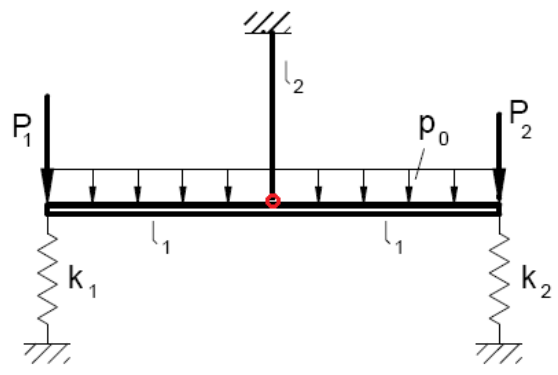
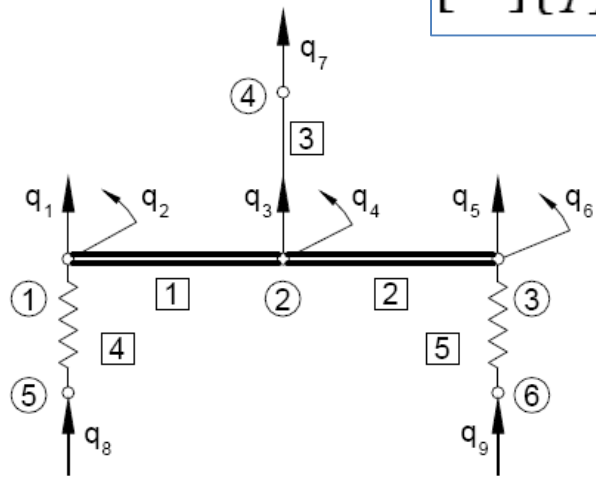
$$[K]_{9 \times 9} = \begin{bmatrix} k_{11}^1 + k_{22}^4 & k_{12}^1 & k_{13}^1 & k_{14}^1 & 0 & 0 & 0 & k_{12}^4 & 0 \\ k_{21}^1 & k_{22}^1 & k_{23}^1 & k_{24}^1 & 0 & 0 & 0 & 0 & 0 \\ k_{31}^1 & k_{32}^1 & k_{33}^1 + k_{11}^2 + k_{11}^3 & k_{34}^1 + k_{12}^2 & k_{13}^2 & k_{14}^2 & k_{12}^3 & 0 & 0 \\ k_{41}^1 & k_{42}^1 & k_{43}^1 + k_{21}^2 & k_{44}^1 + k_{22}^2 & k_{23}^2 & k_{24}^2 & 0 & 0 & 0 \\ 0 & 0 & k_{31}^2 & k_{32}^2 & k_{33}^2 + k_{22}^5 & k_{34}^2 & 0 & 0 & k_{12}^5 \\ 0 & 0 & k_{41}^2 & k_{42}^2 & k_{43}^2 & k_{44}^2 & 0 & 0 & 0 \\ 0 & 0 & k_{21}^3 & 0 & 0 & 0 & k_{11}^3 & 0 & 0 \\ k_{21}^4 & 0 & 0 & 0 & 0 & 0 & 0 & k_{11}^4 & 0 \\ 0 & 0 & 0 & 0 & k_{21}^5 & 0 & 0 & 0 & k_{11}^5 \end{bmatrix}$$

Układ równań: $[K]\{q\} = \{F\}$



-  - No 1 (beam)
-  - No 2 (beam)
-  - No 3 (rod)
-  - No 4 (spring)
-  - No 5 (spring)

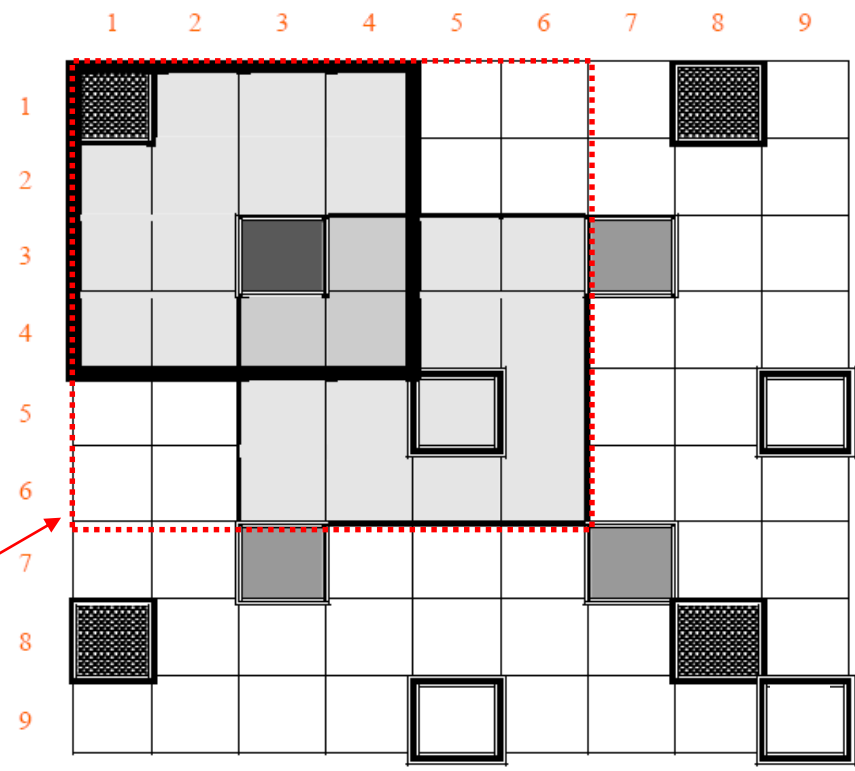

$$\begin{Bmatrix} q_1 \\ q_2 \\ q_3 \\ q_4 \\ q_5 \\ q_6 \\ 0 \\ 0 \\ 0 \end{Bmatrix} = \begin{Bmatrix} \frac{-p_0 l_1}{2} - P_1 \\ \frac{-p_0 l_1^2}{12} \\ -p_0 l_1 \\ 0 \\ \frac{-p_0 l_1}{2} - P_2 \\ \frac{p_0 l_1^2}{12} \\ F_7 \\ F_8 \\ F_9 \end{Bmatrix}$$

Układ równań do rozwiązania:

Przykład Belka wspornikowa z przegubem

Zbuduj model MES (użyj 2 elementów). Wyznacz przemieszczenia, reakcje i siły wewnętrzne. Sprawdź warunki równowagi.

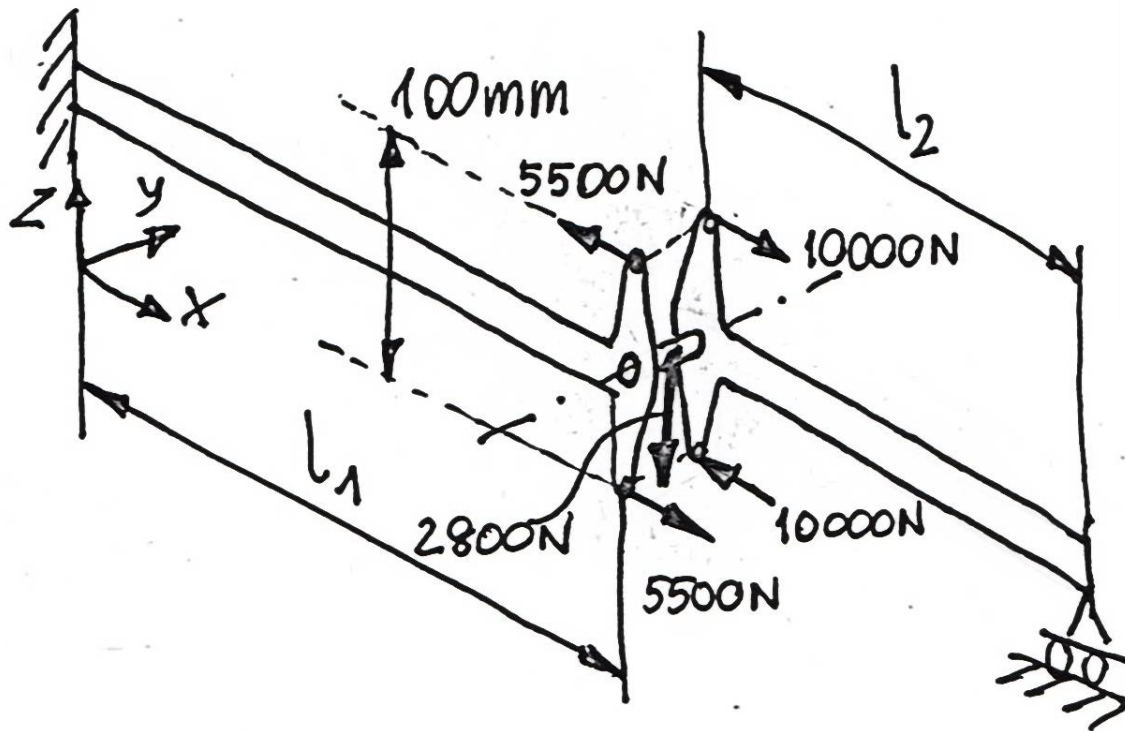

$$E = 2 \cdot 10^5 \text{ MPa}$$

$$l_1 = 1000 \text{ mm}$$

$$l_2 = 500 \text{ mm}$$

$$J_{y_1} = 1.143 \cdot 10^5 \text{ mm}^4$$

$$J_{y_2} = 1.621 \cdot 10^5 \text{ mm}^4$$

Parametry węzłowe:

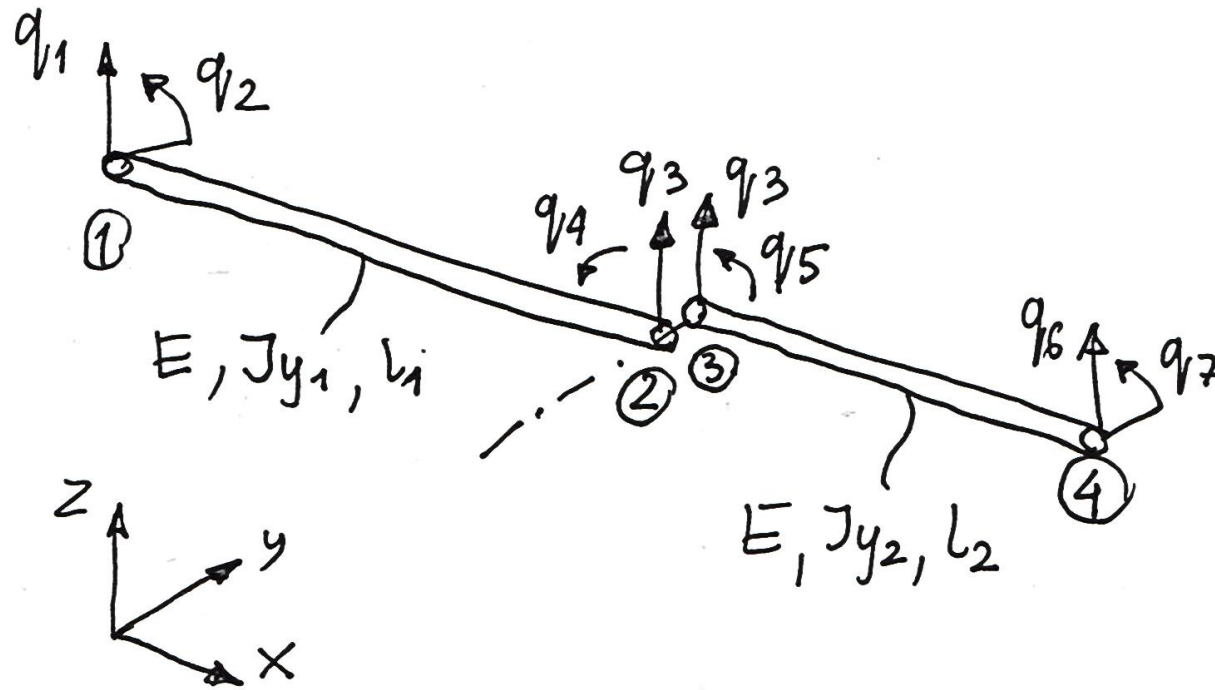

$$\underset{1 \times 7}{Lq} = Lq_1, q_2, q_3, q_4, q_5, q_6, q_7$$

Obciążenia i reakcje:

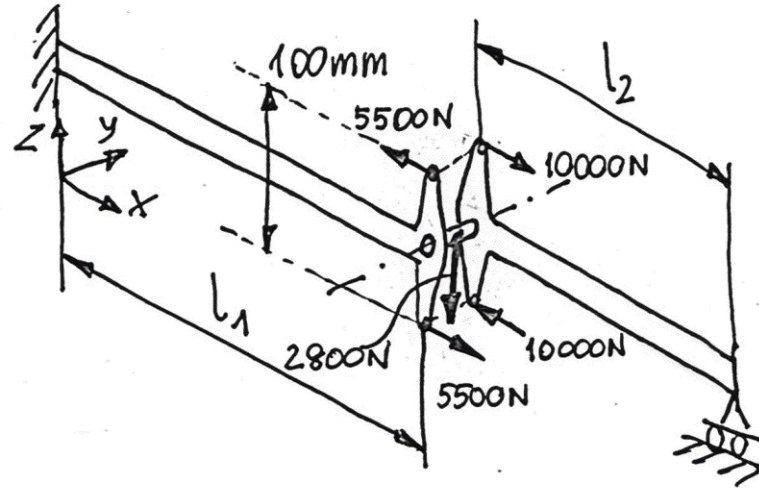

$$M_1 = 5500\text{N} \cdot 100\text{mm} = 0.55 \cdot 10^6 \text{ Nmm}$$

$$M_2 = 10000\text{N} \cdot 100\text{mm} = 1 \cdot 10^6 \text{ Nmm}$$

$$F = 2800\text{N}$$

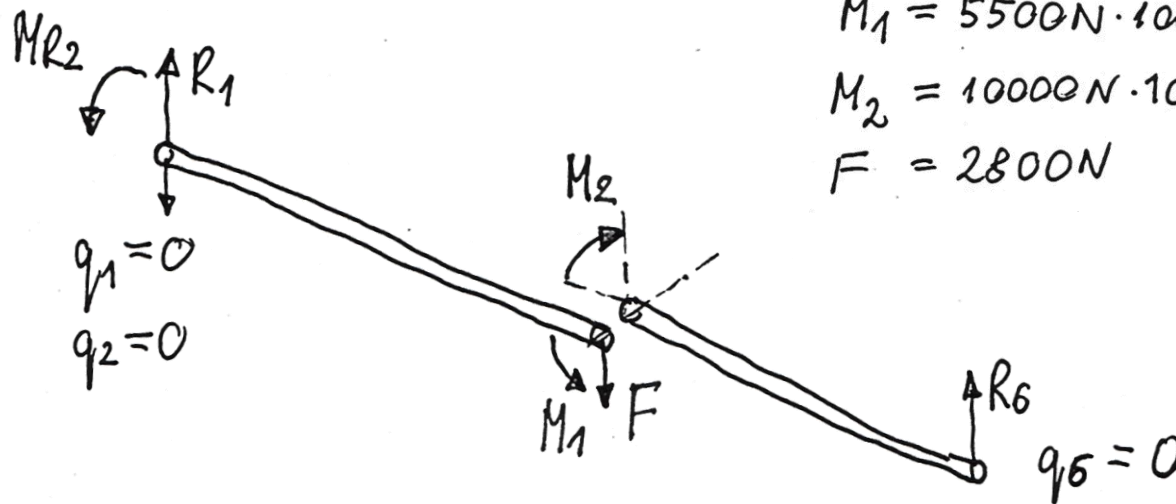

$$\underset{1 \times 7}{[F]} = [R_1, M_{R2}, -F, M_1, -M_2, R_6, 0]$$

Macierze sztywności:

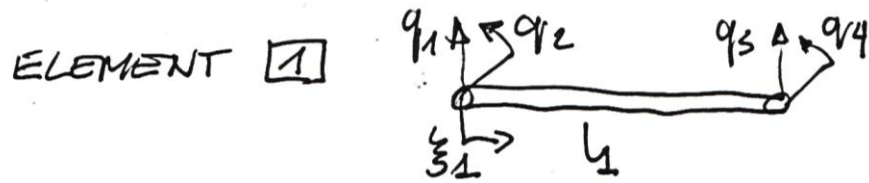

$$[K]_1 = \frac{2EJy_1}{l_1^3} \begin{bmatrix} 6 & 3l_1 & -6 & 3l_1 \\ 3l_1 & 2l_1^2 & -3l_1 & l_1^2 \\ -6 & -3l_1 & 6 & -3l_1 \\ 3l_1 & l_1^2 & -3l_1 & 2l_1^2 \end{bmatrix} ;$$

$$[K]_1^* = \begin{bmatrix} \text{shaded } [K]_1 & [0]_{4 \times 3} \\ [0]_{3 \times 4} & [0]_{3 \times 3} \end{bmatrix}$$

7x7

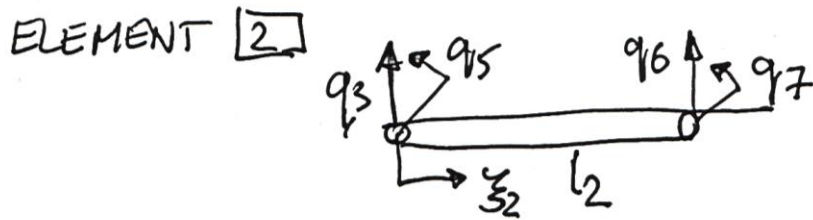

$$[K]_2 = \frac{2EJy_2}{l_2^3} \begin{bmatrix} 6 & 3l_2 & -6 & 3l_2 \\ 3l_2 & 2l_2^2 & -3l_2 & l_2^2 \\ -6 & -3l_2 & 6 & -3l_2 \\ 3l_2 & l_2^2 & -3l_2 & 2l_2^2 \end{bmatrix} ;$$

$$[K]_2^* = \begin{bmatrix} 0 & 0 & 0 & 0 & 0 & 0 & 0 & 0 \\ 0 & 0 & 0 & 0 & 0 & 0 & 0 & 0 \\ 0 & 0 & \text{shaded } [K]_2 & 0 & 0 & 0 & 0 & 0 \\ 0 & 0 & 0 & 0 & 0 & 0 & 0 & 0 \\ 0 & 0 & 0 & 0 & \text{shaded } [K]_2 & 0 & 0 & 0 \\ 0 & 0 & 0 & 0 & 0 & 0 & 0 & 0 \\ 0 & 0 & 0 & 0 & 0 & 0 & 0 & 0 \\ 0 & 0 & 0 & 0 & 0 & 0 & 0 & 0 \end{bmatrix}$$

7x7

Globalna macierz sztywności:

$$[K]_{7 \times 7} = [k]_1^* + [k]_2^* =$$

				0	c	0
				c	0	0
				0	0	0
c	0		c			
0	0		0			
c	c		0			

Warunki brzegowe:

$$q_1 = 0, q_2 = 0, q_6 = 0 \Rightarrow N = \text{NDOF} - \text{DOF} = 4$$

$$\underbrace{\begin{bmatrix} \text{hatched} & \text{hatched} & \text{hatched} & \text{hatched} \\ \text{hatched} & \text{hatched} & 0 & 0 \\ \text{hatched} & 0 & \text{hatched} & \text{hatched} \\ \text{hatched} & 0 & \text{hatched} & \text{hatched} \end{bmatrix}}_{[K]_{4 \times 4}} \cdot \begin{Bmatrix} q_3 \\ q_4 \\ q_5 \\ q_7 \end{Bmatrix} = \begin{Bmatrix} -F \\ M_1 \\ -M_2 \\ 0 \end{Bmatrix}$$

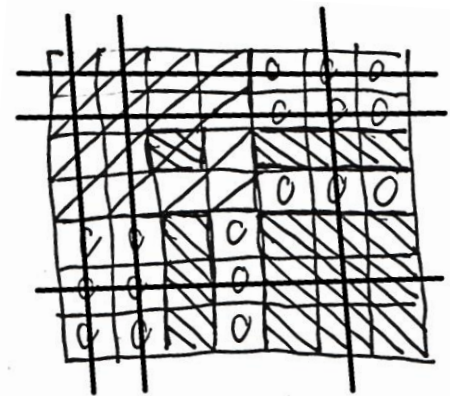

$$[K]_{4 \times 4} = \begin{bmatrix} \frac{12EJy_1}{l^3} + \frac{12EJy_2}{l^3} & -\frac{6EJy_1}{l^2} & \frac{6EJy_2}{l^2} & \frac{6EJy_2}{l^2} \\ -\frac{6EJy_1}{l^2} & \frac{4EJy_1}{l} & 0 & 0 \\ \frac{6EJy_2}{l^2} & 0 & \frac{4EJy_2}{l} & \frac{2EJy_2}{l} \\ \frac{6EJy_2}{l^2} & 0 & \frac{2EJy_2}{l} & \frac{4EJy_2}{l} \end{bmatrix}$$

$$a = \frac{12EJy_1}{l^3} + \frac{12EJy_2}{l^3}$$

$$b = -\frac{6EJy_1}{l^2}, \quad c = \frac{6EJy_2}{l^2}$$

$$d = \frac{4EJy_1}{l}, \quad f = \frac{4EJy_2}{l}$$

$$[K]_{4 \times 4} = \begin{bmatrix} a & b & c & c \\ b & d & 0 & 0 \\ c & 0 & f & f/2 \\ c & 0 & f/2 & f \end{bmatrix}$$

$$\begin{cases} a q_3 + b q_4 + c q_5 + c q_7 = -F \\ b q_3 + d q_4 = M_1 \\ c q_3 + f q_5 + \frac{f}{2} q_7 = -M_2 \\ c q_3 + \frac{f}{2} q_5 + f \cdot q_7 = 0 \end{cases}$$

$$\begin{aligned} \text{III} - \text{IV} : \quad & \frac{f}{2} q_5 - \frac{f}{2} q_7 = -M_2 \Rightarrow q_5 = q_7 - \frac{2M_2}{f} \\ \text{III} : \quad & c q_3 + f \left(q_7 - \frac{2M_2}{f} \right) + \frac{f}{2} q_7 = -M_2 \\ & c q_3 + \frac{3}{2} f \cdot q_7 = M_2 \Rightarrow q_7 = \frac{2(M_2 - c q_3)}{3f} \\ \text{II} : \quad & q_4 = \frac{M_1 - b q_3}{d} \\ \rightarrow \quad & q_5 = \frac{2(M_2 - c q_3)}{3f} - \frac{2M_2}{f} = -\frac{4M_2 + 2c q_3}{3f} \end{aligned}$$

I:

$$a \cdot q_3 + b \left(\frac{M_1 - b q_3}{d} \right) - c \cdot \frac{4M_2 + 2c q_3}{3f} + c \cdot \frac{2(M_2 - c q_3)}{3f} = -F$$

$$a \cdot q_3 + \frac{b}{d} M_1 - \frac{b^2}{d} q_3 - \frac{4M_2 c}{3f} - \frac{2c^2 q_3}{3f} + \frac{2M_2 c}{3f} - \frac{2c^2 q_3}{3f} = -F$$

$$\left(a - \frac{b^2}{d} - \frac{4c^2}{3f} \right) q_3 = -F - \frac{b}{d} M_1 + \frac{2cM_2}{3f}$$

$$q_3 = \frac{\frac{2cM_2}{3f} - F - \frac{b}{d} M_1}{\left(a - \frac{b^2}{d} - \frac{4c^2}{3f} \right)} = \frac{\frac{2 \cdot 6EJy_2 \cdot M_2 \cdot l_2}{3 \cdot l_2^2 \cdot 4EJy_2} - F + \frac{6EJy_1 \cdot M_1 \cdot l_1}{l_1^2 \cdot 4 \cdot EJy_1}}{\left(a - \frac{b^2}{d} - \frac{4c^2}{3f} \right)}$$

$$a - \frac{b^2}{d} - \frac{4c^2}{3f} = \frac{12EJy_1}{l_1^3} + \frac{12EJy_2}{l_2^3} - \frac{36E^2 Jy_1^2 \cdot l_1}{l_1^4 \cdot 4EJy_1} - \frac{4 \cdot 36E^2 Jy_2^2 \cdot l_2}{3 \cdot l_2^4 \cdot 4EJy_2} = \frac{3EJy_1}{l_1^3}$$

$$q_3 = \frac{\left(\frac{3}{2} \frac{M_1}{l_1} + \frac{M_2}{l_2} - F \right) l_1^3}{3EJy_1}$$

Poszukiwane przemieszczenia węzłowe:

$$q_3 = \frac{\left(\frac{3}{2} \frac{M_1}{l_1} + \frac{M_2}{l_2} - F\right) l_1^3}{3 E J y_1} = 0.3645 \text{ mm.}$$

$$q_4 = \frac{\left(M_1 + \frac{M_2 l_1}{2 l_2} - \frac{F l_1}{2}\right) l_1}{E J y_1} = 6.5617 \cdot 10^{-3} = 0.38^\circ$$

$$q_5 = - \frac{M_2 l_2 + \frac{J y_2 l_1^3}{J y_1 l_2} \left(\frac{3}{2} \frac{M_1}{l_1} + \frac{M_2}{l_2} - F\right)}{3 E J y_2} = -5.8699 \cdot 10^{-3} = -0.34^\circ$$

$$q_7 = \frac{\frac{1}{2} M_2 l_2 - \frac{J y_2 l_1^3}{J y_1 l_2} \left(\frac{3}{2} \frac{M_1}{l_1} + \frac{M_2}{l_2} - F\right)}{3 E J y_2} = 1.8415 \cdot 10^{-3} = 0.11^\circ$$

Reakcje:

$[K] =$
7x7

0	0	0	0	0	0	0
0	0	0	0	0	0	0
0	0	0	0	0	0	0
0	0	0	0	0	0	0
0	0	0	0	0	0	0
0	0	0	0	0	0	0
0	0	0	0	0	0	0

$$R_1 = -\frac{12 E J y_1}{l_1^3} \cdot q_3 + \frac{6 E J y_1}{l_1^2} \cdot q_4 =$$

$$= -4 \left(\frac{3 M_1}{2 l_1} + \frac{M_2}{l_2} - F \right) + \frac{6}{l_1} \left(M_1 + \frac{M_2 l_1}{2 l_2} - \frac{F l_1}{2} \right) = F - \frac{M_2}{l_2} = 800 \text{ N}$$

$$M_{R2} = -\frac{6 E J y_1}{l_1^2} \cdot q_3 + \frac{2 E J y_1}{l_1} q_4$$

$$= -2 l_1 \left(\frac{3 M_1}{2 l_1} + \frac{M_2}{l_2} - F \right) + 2 \left(M_1 + \frac{M_2 l_1}{2 l_2} - \frac{F l_1}{2} \right) =$$

$$= -\left(3 M_1 + 2 \frac{M_2 l_1}{l_2} - 2 F l_1 \right) + 2 M_1 + M_2 \frac{l_1}{l_2} - F l_1 =$$

$$= F l_1 - M_1 - M_2 \frac{l_1}{l_2} = 0.25 \cdot 10^6 \text{ Nmm}$$

$$R_6 = -\frac{12EIy_2}{l_2^3} \cdot q_3 + 0 \cdot q_4 - \frac{6EIy_2}{l_2^2} \cdot q_5 - \frac{6EIy_2}{l_2^2} \cdot q_7 =$$

$$= -\frac{12EIy_2}{l_2^3} \cdot \frac{\left(\frac{3}{2} \frac{M_1}{l_1} + \frac{M_2}{l_2} - F\right) l_1^3}{3EIy_1} +$$

$$- \frac{6EIy_2}{l_2^2} \cdot \left(-\frac{M_2 l_2 + \frac{J_{y2}}{J_{y1}} \frac{l_1^3}{l_2} \left(\frac{3}{2} \frac{M_1}{l_1} + \frac{M_2}{l_2} - F\right)}{3EIy_2} \right) +$$

$$- \frac{6EIy_2}{l_2^2} \cdot \left(\frac{\frac{1}{2} M_2 l_2 - \frac{J_{y2}}{J_{y1}} \frac{l_1^3}{l_2} \left(\frac{3}{2} \frac{M_1}{l_1} + \frac{M_2}{l_2} - F\right)}{3EIy_2} \right) =$$

$$= -4 \frac{J_{y2}}{J_{y1}} \frac{l_1^3}{l_2^3} \left(\frac{3}{2} \frac{M_1}{l_1} + \frac{M_2}{l_2} - F\right) +$$

$$+ 2 \left(\frac{M_2}{l_2} + \frac{J_{y2}}{J_{y1}} \frac{l_1^3}{l_2^3} \left(\frac{3}{2} \frac{M_1}{l_1} + \frac{M_2}{l_2} - F\right) \right) +$$

$$- 2 \left(\frac{1}{2} \frac{M_2}{l_2} - \frac{J_{y2}}{J_{y1}} \frac{l_1^3}{l_2^3} \left(\frac{3}{2} \frac{M_1}{l_1} + \frac{M_2}{l_2} - F\right) \right) = \frac{M_2}{l_2} = 2000 \text{ N}$$

Sprawdzenie równowagi:

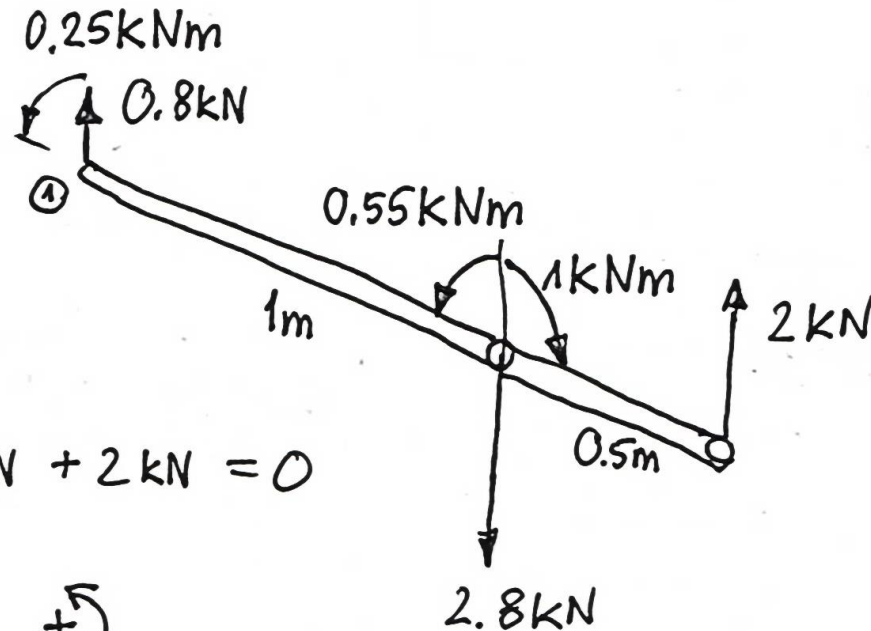

$$\sum F_z = 0$$

$$0.8 \text{ kN} - 2.8 \text{ kN} + 2 \text{ kN} = 0$$

$$\sum M_y^{\textcircled{1}} = 0 \quad +\curvearrowright$$

$$0.25 \text{ kNm} + 0.55 \text{ kNm} - 1 \text{ kNm} - 2.8 \text{ kN} \cdot 1 \text{ m} + 2 \text{ kN} \cdot 1.5 \text{ m} = 0$$

Rozwiązania elementowe:

ugięcie:

[1]

$$w_1(\xi_1) = \underset{1 \times 4}{[N]} \cdot \underset{4 \times 1}{\{q\}_1} = [N_1, N_2, N_3, N_4] \cdot \begin{Bmatrix} 0 \\ 0 \\ q_3 \\ q_4 \end{Bmatrix} =$$

$$= N_3 \cdot q_3 + N_4 \cdot q_4 =$$

$$= \left(\frac{3}{l_1^2} \cdot \xi_1^2 - \frac{2}{l_1^3} \cdot \xi_1^3 \right) \cdot q_3 + \left(\frac{1}{l_1^2} \cdot \xi_1^3 - \frac{1}{l_1} \xi_1^2 \right) q_4$$

$$w_1(0) = 0, \quad w_1(l_1) = (3-2)q_3 + (1-1)q_4 = q_3$$

$$\frac{dw_1}{d\xi} = \left(\frac{6}{l_1^2} \xi_1 - \frac{6}{l_1^3} \xi_1^2 \right) q_3 + \left(\frac{3}{l_1^2} \xi_1^2 - \frac{2}{l_1} \xi_1 \right) q_4$$

$$\left. \frac{dw_1}{d\xi_1} \right|_{625\text{mm}} = 0 \Rightarrow w_{1\text{min}} = w_1(625) = -0.712\text{mm}$$

Moment gnaący:

$$\begin{aligned} M_{y_1}(\xi_1) &= w_1'' E J_{y_1} = E J_{y_1} \cdot (N_3'' \cdot q_3 + N_4'' \cdot q_4) = \\ &= E J_{y_1} \cdot \left(\left(\frac{6}{l_1^2} - \frac{12}{l_1^3} \xi_1 \right) \cdot q_3 + \left(\frac{6}{l_1^2} \xi_1 - \frac{2}{l_1} \right) q_4 \right) \end{aligned}$$

$$M_{y_1}(0) = -0.25 \cdot 10^6 \text{ Nmm}$$

$$M_{y_1}(l_1) = 0.55 \cdot 10^6 \text{ Nmm} = M_1$$

Siła tnąca:

$$\begin{aligned} T_{z_1}(\xi_1) &= -w_1''' E J_{y_1} = -E J_{y_1} (N_3''' \cdot q_3 + N_4''' \cdot q_4) = \\ &= +E J_{y_1} \cdot \left(\frac{12}{l_1^3} q_3 - \frac{6}{l_1^2} q_4 \right) = -800 \text{ N} \end{aligned}$$

2

ugięcie:

$$w_2(\xi_2) = \underline{N} \cdot \{q\}_2 = \underline{[N_1, N_2, N_3, N_4]} \cdot \begin{Bmatrix} q_3 \\ q_5 \\ 0 \\ q_7 \end{Bmatrix} =$$

$$= N_1 \cdot q_3 + N_2 \cdot q_5 + N_4 \cdot q_7 =$$

$$= \left(1 - \frac{3}{l_2} \xi_2^2 + \frac{2}{l_2^3} \xi_2^3\right) q_3 + \left(\xi_2 - \frac{2}{l_2} \xi_2^2 + \frac{1}{l_2^2} \xi_2^3\right) q_5 + \left(\frac{1}{l_2} \xi_2^3 - \frac{1}{l_2} \xi_2^2\right) q_7$$

$$w_2(0) = q_3$$

$$w_2(l_2) = (1 - 3 + 2) q_3 + (l_2 - 2l_2 + l_2) q_5 + (l_2 - l_2) q_7 = 0$$

$$\frac{dw_2}{d\xi_2} = \left(\frac{6}{l_2^3} \xi_2^2 - \frac{6}{l_2^2} \xi_2\right) q_3 + \left(1 - \frac{4}{l_2} \xi_2 + \frac{3}{l_2^2} \xi_2^2\right) q_5 + \left(\frac{3}{l_2^2} \xi_2^2 - \frac{2}{l_2} \xi_2\right) q_7$$

$$\left. \frac{dw_2}{d\xi_2} \right|_{255.7 \text{ mm}} = 0 \Rightarrow w_{2 \min} = w_2(255.7) = -0.3 \text{ mm}$$

Moment gnaący:

$$M_{y_2}(\xi_2) = W_2'' E J_{y_2} = E J_{y_2} (N_1'' \cdot q_3 + N_2'' \cdot q_5 + N_4'' \cdot q_7) =$$
$$= E J_{y_2} \cdot \left(\left(\frac{12}{l_2^3} \xi_2 - \frac{6}{l_2^2} \right) q_3 + \left(\frac{6}{l_2^2} \xi_2 - \frac{4}{l_2} \right) q_5 + \left(\frac{6}{l_2^2} \xi_2 - \frac{2}{l_2} \right) q_7 \right)$$

$$M_{y_2}(0) = 1 \cdot 10^6 \text{ Nmm} = M_2$$

$$M_{y_2}(l_2) = 0$$

Siła tnąca:

$$T_{z_2} = -W_2''' \cdot E J_{y_2} = -E J_{y_2} \cdot (N_1''' \cdot q_3 + N_2''' \cdot q_5 + N_4''' \cdot q_7) =$$
$$= -E J_{y_2} \cdot \left(\frac{12}{l_2^3} q_3 + \frac{6}{l_2^2} q_5 + \frac{6}{l_2^2} q_7 \right) = 2000 \text{ N}$$

Funkcja ugięcia i rozkłady sił wewnętrznych:

